



ADDENDUM NO. 2

**TO THE CONTRACT DOCUMENTS FOR
Davis Pressure Plane Phase 2
PROJECT NO. WUWS17001**

November 12, 2021

The following instructions shall constitute **Addendum No. 2** to the Plans and Specifications for the above titled project. **The Bidder shall acknowledge receipt of the addendum either on the front of the bid envelope OR in the appropriate spaces provided on the last page of the addendum and include the acknowledgment/acceptance in the sealed bid.** They shall supersede any and all instructions and shall become as much a part of the Plans and Specifications as though written therein. The successful bidder shall also acknowledge acceptance of the addendum on the final contract:

I. REVISION TO SECTION NO. 6 - PROPOSAL:

1. REVISE Base Bid Items

Item No.	Quantity & Unit	Description & Price In Words	Prices in Figures	
			Unit Price	TOTAL
411	450 SY	Remove and Replace TxDOT Continuously Reinforced Concrete Pavement (CRCP) per details, including reinforcing steel, blockouts & joints, and HMAC underlayment , complete and in place for the sum of _____ dollars and _____ cents per Square Yard.	\$	\$
414	230 SY	Remove and Replace Reinforced Concrete Median over compacted subgrade to 95% density per ASTM D698, complete and in place for the sum of _____ dollars and _____ cents per Square Yard.	\$	\$
415	95 SY	Remove and Replace Brick Pavers Median (approximately Sta. 36+75 to Sta. 38+50) over compacted subgrade to 95% density per ASTM D698 per MEDIAN NOSE PAVERS detail, complete and in place for the sum of _____ dollars and _____ cents per Square Yard.	\$	\$
418	420 SY	Remove and Replace 4-inch thick Reinforced Concrete Sidewalks over compacted native soil per Project Inspector's direction, complete and in place for the sum of _____ dollars and _____ cents per Square Yard.	\$	\$

Item No.	Quantity & Unit	Description & Price In Words	Prices in Figures	
			Unit Price	TOTAL
528	110 SY	Remove and Replace TxDOT Reinforced Concrete Pavement, including reinforcing steel, blockouts & joints, and HM AC underlayment , complete and in place for the sum of _____ dollars and _____ cents per Square Yard.	\$	\$

2. ADD Base Bid Items

433	20 SY	Remove and Replace Brick Paver Nose with Concrete Monolithic Nose per MEDIAN NOSE PAVERS detail, complete and in place for the sum of _____ dollars and _____ cents per Square Yard.	\$	\$
-----	-------	---	----	----

TOTAL BASE BID SUMMARY

MOBILIZATION & SWPPP \$ 210,000.00
(Items 101 – 102)

WATER IMPROVEMENTS \$ _____
(Items 201 – 257)

SANITARY SEWER IMPROVEMENTS \$ _____
(Items 301 - 327)

PAVING IMPROVEMENTS \$ _____
(Items 401 - 433)

WATER IMPROVEMENTS FOR UTA BLVD \$ _____
(Items 501 – 530)

TOTAL BASE BID \$ _____

TOTAL BASE BID + ALTERNATE A \$ _____

II. ADDITION TO CONSTRUCTION PLAN:

- Attached MEDIAN NOSE PAVERS detail is added to Addendum #2 as part of the details of this project.

ACKNOWLEDGEMENT/ACCEPTANCE:

The undersigned does hereby agree to the additions, stipulations, and terms outlined in **Addendum No. 2** to the Plans and Specifications for the **Davis Pressure Plane Phase 2, City of Arlington Project No. WUWS17001**.

The bidder shall acknowledge his/her Addendum in the appropriate space below and **include it in the bid proposal otherwise the bid will be considered as non-responsive.**

Lori Du

Lori Du, P.E.
Civil Engineer

CONTRACTOR

Company

By:

Please Print

Signature

Print Title

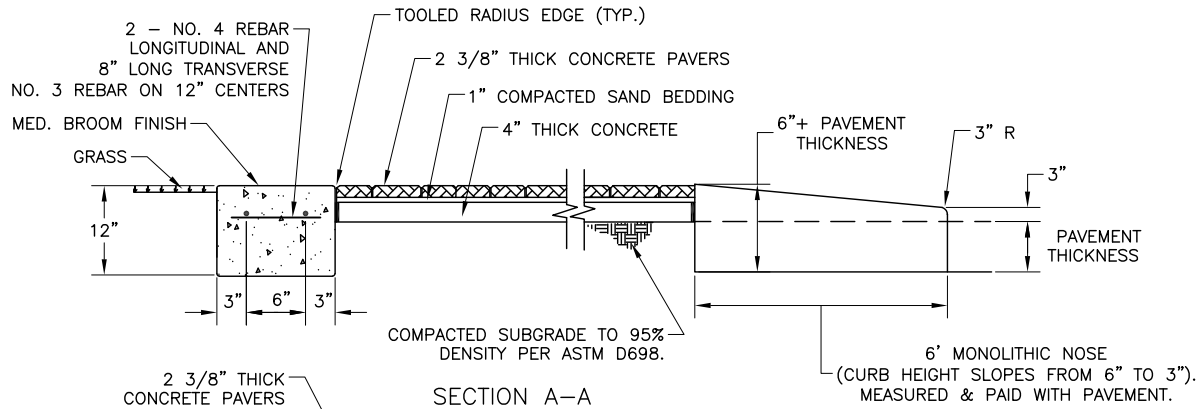

SECTION A-A
NTS

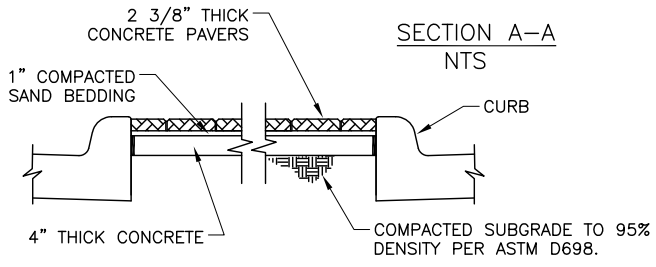

SECTION B-B
NTS

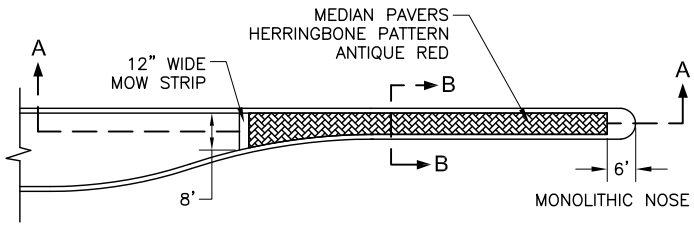

MEDIAN LESS THAN 8 FEET WIDE
NTS

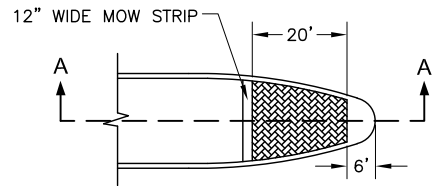

MEDIAN GREATER THAN 8 FEET WIDE
NTS

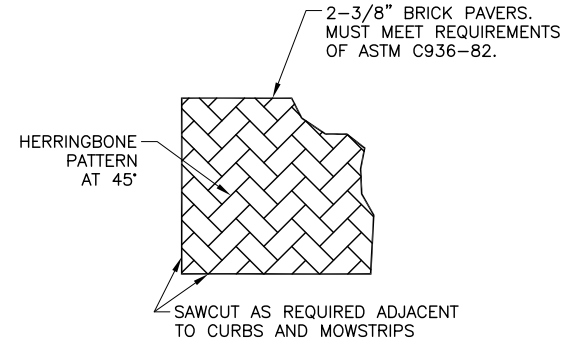

CONCRETE PAVER PATTERN
NTS

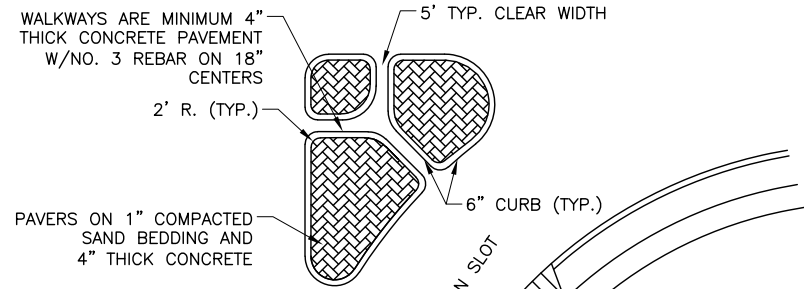

TYPICAL ISLAND AT INTERSECTION
NTS

NOTES:

1. CONCRETE SHALL BE CLASS C, 5 1/2 SACK, 3600 PSI.
2. INTERLOCKING CONCRETE PAVER HERRINGBONE PATTERN, ANTIQUE RED AS APPROVED BY THE CITY.
3. 3/4" ASPHALT EXPANSION JOINT MATERIAL ANY PLACE WHERE CONCRETE ABUTS CONCRETE.
4. STEEL REINFORCING UNDER MEDIAN NOSE IS SAME AS PAVEMENT REQUIREMENT.
5. CONCRETE UNDER PAVERS IS NON-REINFORCED.
6. SAND SHALL BE IN ACCORDANCE WITH PAVESTONE INC. RECOMMENDATIONS OR APPROVED EQUAL.
7. ALL CONCRETE AND BRICK SHALL BE WET SAWED.

MEDIAN NOSE PAVERS
NTS REV: 7/18/17

 CITY OF ARLINGTON, TEXAS		
MEDIAN NOSE PAVERS		
DATE:	SCALE: NTS	SHEET: OF
DESIGNED BY:	DRAWN BY:	CHECKED BY: