

02/06/18

N.T.S.

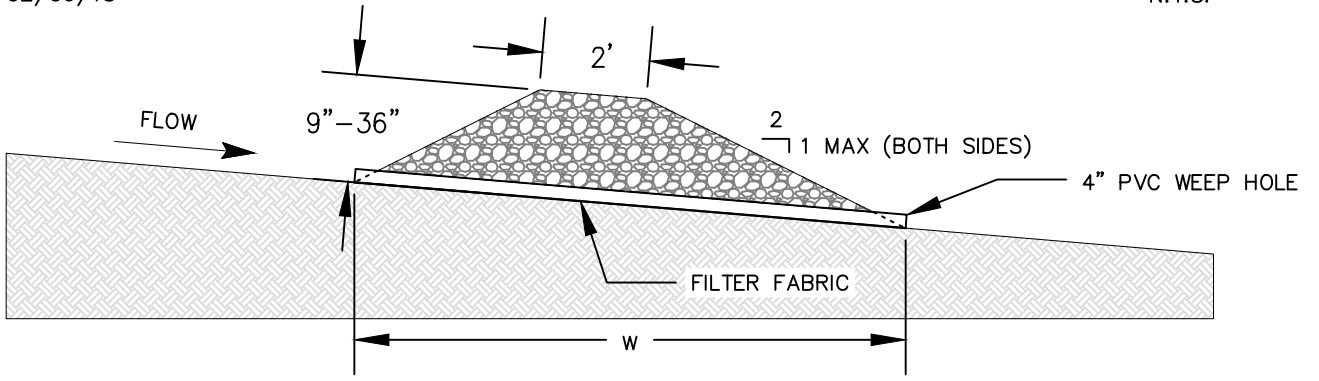

02/06/18

N.T.S.

GENERAL DESIGN NOTES:

1. IF SHOWN ON THE PLANS OR DIRECTED BY THE CITY, CHECK DAMS SHALL BE PLACED NEAR THE TOE OF SLOPES WHERE EROSION IS ANTICIPATED, UPSTREAM AND/OR DOWNSTREAM AT DRAINAGE STRUCTURES, AND IN ROADWAY DITCHES AND CHANNELS TO COLLECT SEDIMENT.
2. THE HEIGHT OF THE CHECK DAM SHALL ALWAYS BE LESS THAN ONE-THIRD THE DEPTH OF THE CHANNEL.
3. CHECK DAMS SHALL BE SPACED SUCH THAT THE TOP OF THE DOWNSTREAM DAM IS AT THE SAME ELEVATION AS THE TOE OF THE UPSTREAM DAM. ON CHANNEL GRADES LESS THAN 0.4 PERCENT, CHECK DAMS SHALL BE PLACED AT A DISTANCE THAT ALLOWS SMALL POOLS TO FORM BETWEEN EACH CHECK DAM.
4. THE SIDE OF THE DAMS SHALL BE EMBEDDED A MINIMUM OF 18 INCHES INTO THE SIDE OF THE DRAINAGE DITCH, SWALE OR CHANNEL TO MINIMIZE THE POTENTIAL FOR FLOWS TO ERODE AROUND THE SIDE OF THE DAM.
5. LARGER FLOWS (GREATER THAN 2-YEAR, 24-HOUR DESIGN STORM) MUST PASS THE CHECK DAM WITHOUT CAUSING EXCESSIVE UPSTREAM FLOODING.
6. ROCK CHECK DAMS SHALL BE INSPECTED REGULARLY. REMOVE SILT WHEN IT REACHES APPROXIMATELY ONE-THIRD THE HEIGHT OF THE DAM OR 12 INCHES, WHICHEVER IS LESS.
7. CONTRACTOR SHALL BE RESPONSIBLE TO MAINTAIN THE DRAIN PIPE TO ENSURE PROPER FLOW.

GENERAL MATERIALS NOTES:

1. STONE SHALL BE WELL GRADED WITH STONE SIZE RANGING FROM 3 TO 6 INCHES IN DIAMETER FOR A CHECK DAM HEIGHT OF 24 INCHES OR LESS. THE STONE SIZE RANGE FOR CHECK DAMS GREATER THAN 24 INCHES IN HEIGHT SHALL BE 4 TO 8 INCHES IN DIAMETER. THE USE OF TEMPORARY GABION STRUCTURES SHALL BE APPROVED BY THE CITY.
2. SEPARATION FILTER FABRIC MATERIALS AND CONSTRUCTION METHODS TO CONFORM TO CITY OF ARLINGTON STANDARDS AND SPECIFICATIONS.

CITY OF ARLINGTON, TEXAS		
ROCK CHECK DAM		
DATE: 02/06/18	SCALE: NTS	SHEET ____ OF ____
DESIGNED BY: KDC	DRAWN BY: KDC	CHECKED BY: