

DuMOR INC, PARTS LIST

ITEM	QTY	PART NO.	DESCRIPTION
1	1	0-400-02	STL BOLLARD SLEEVE W/ HINGE
2	1	0-400-03	BOLLARD SLEEVE CAP ASSEMBLY
3	1	0-400-42-01/1SL	42" STL BOLLARD, EMBED FOR SLEEVE

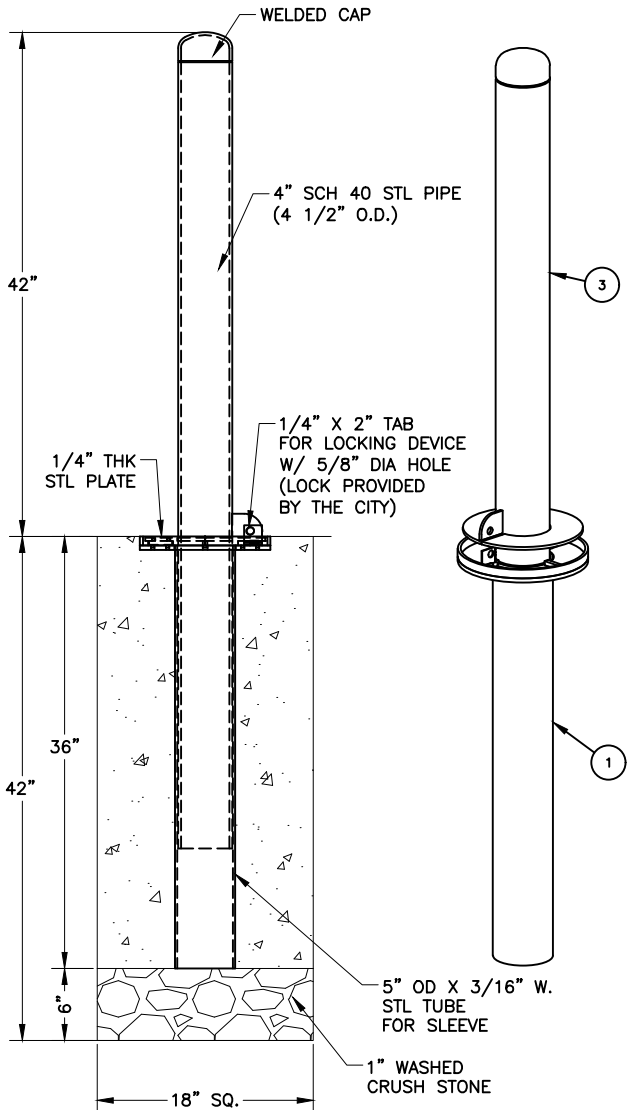

DETAIL OF BOLLARD WITH SLEEVE

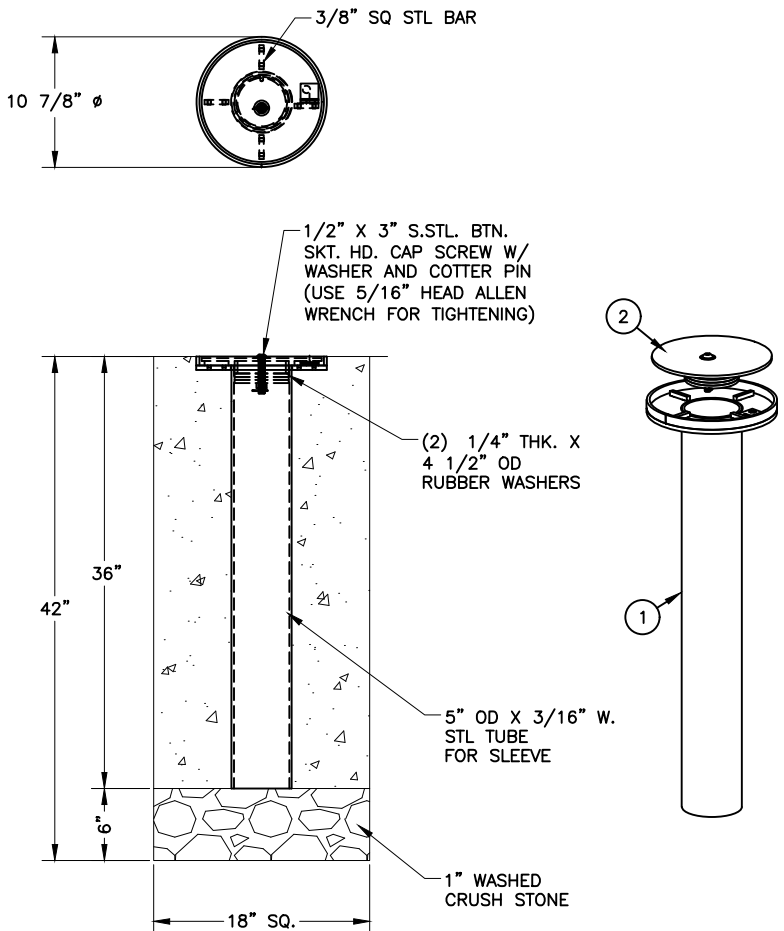

DETAIL OF SLEEVE WITH CAP

BOLLARD

NTS

9/12/17

NOTES:

1. BOLLARD SHALL BE DuMOR, INC. OR APPROVED EQUAL
2. STL. MEMBERS COATED W/ ZINC RICH EPOXY THEN FINISHED W/ POLYESTER POWDER COATING WHICH SHALL BE "SAFETY YELLOW" IN COLOR.
3. SET SLEEVE INTO FOOTER HOLDING PLUM, SQUARE AND AT HEIGHT SHOWN.
4. SLIDE BOLLARD INTO SLEEVE AFTER CONCRETE HAS HARDENED. BE SURE TO HAVE HINGE TAB SLIDE INTO BOLLARD BASE PLATE SLOT FOR LOCKING.
5. FOR USE OF CAP WHEN BOLLARD IS REMOVED, PLACE CAP INTO SLEEVE. TIGHTEN CAP BY USING 1/2" X 3" BUTTON HEAD BOLT. THIS WILL COMPRESS THE RUBBER WASHERS THICKNESS AND EXPAND THE DIAMETER TO FIT SNUG TO SLEEVE.

CITY OF ARLINGTON, TEXAS		
BOLLARD		
DATE:	SCALE:	SHEET _____ OF _____
DESIGNED BY:	DRAWN BY:	CHECKED BY: